

KNX LED Controller

v.1.1



Important: Read All Instructions Prior to Installation

Function introduction

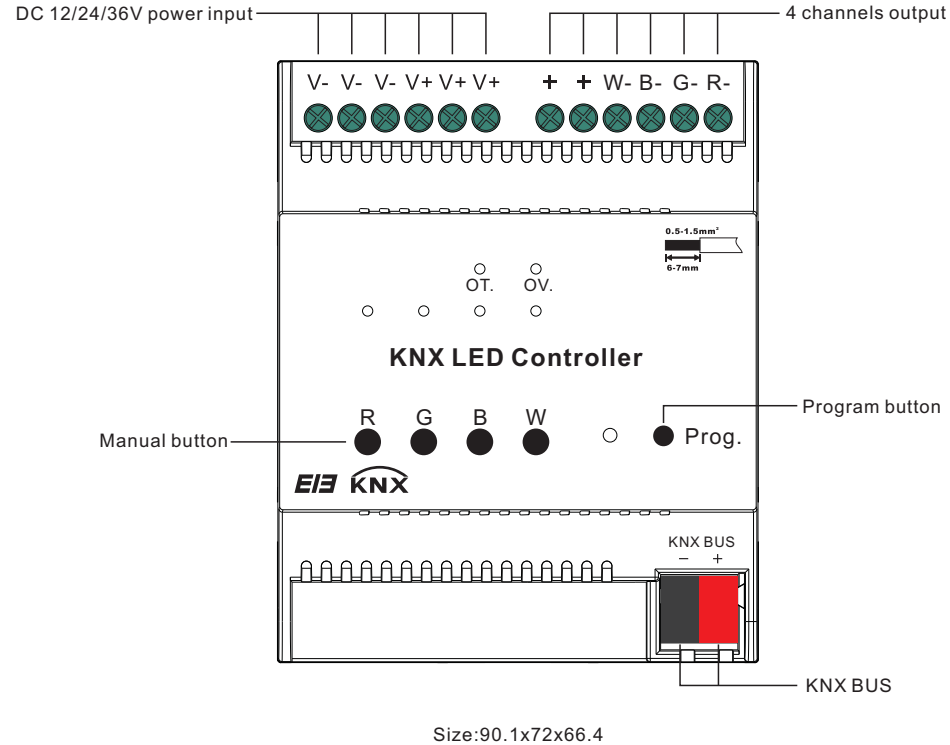

- The dimmer with LED constant voltage drive can drive LED directly, has four channels, each channel is independent.
- The output can connect with some big power dimmable LED lights. These LEDs can be switched, dimmed, recall scene or other operations via the bus.
- The devices adopt PUSH terminals to achieve electrical connection; the connection to the EIB/KNX bus is established via a bus connecting terminal. The input need connect a 12V-36V DC operation voltage. The following list provides a functional overview:
- ☆ Switching the LED light
 - ☆ Relative dimming
 - ☆ Absolute dimming
 - ☆ Status report, error report
 - ☆ Setting 15 scenes
 - ☆ Staircase lighting function
 - ☆ Bus recovery (or reset) function
 - ☆ Preset value and modify preset value functions
 - ☆ Switch/relative dimming via manual buttons

The above function of parameters to configure and use are described in the chapter 5. The device has own database file. There is added a manual operation function in the normal dimming mode, it is invalid in the staircase lighting mode. Switch via a short operation of manual buttons, relative dimming via a long operation, and in the case of the bus voltage fail the manual operation is invalid.

Technical data

Power supply	Bus Operating voltage	21-30V DC, via the KNX/EIB bus		
	Input voltage	12-36V DC	12-36V DC	12-36V DC
Output	Rated current	5Ax4CH	350mAx4CH	700mAx4CH
	Rated power	4x(60-180)W	4x(4.2-12.6)W	4x(8.4-25.2)W
	Load voltage	12-36V DC	12-36V DC	12-36V DC
	Safety	Short-circuit ,over voltage and over temperature protection		
	EIB/KNX	EIB bus connection terminal		
Connections	Inputs/outputs	Using screw connection terminal		
	4 channels			
Operation and display	Button and red LED	For assigning the physical address		
	Green LED flashing	Indicate the application layer running normally		
	LEDs for Output	Indicate output status per channel, LED on mean the channel has output, LED off mean the channel has not output.		
	Manual buttons	Switch via a short operation, relative dimming via a long operation		
	OT. LED	Indicate over-temperature, >70 °C		
	OV. LED	Indicate over voltage, >40V DC		
Type of protection	IP 20 , EN 60 529			
Temperature	Operation	-5 °C...+45°C		
	Storage	-25 °C...+55°C		
	Transport	-25 °C...+70°C		
Ambient	Humidity	<93%, except dewing		

Wiring diagram

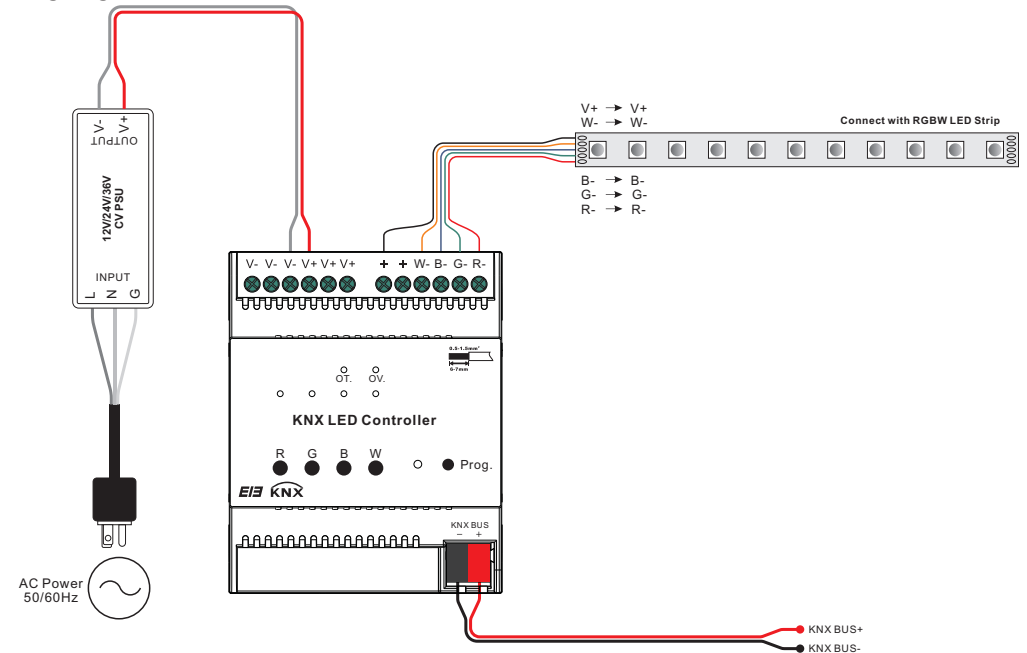

Application Programming

Introduction

It is able to set different parameters to every output channel, and control various targets by modifying the setup of the internal parameters.

Switch

The output can be switched ON or OFF by 1 bit data. It is able to set the brightness value as the last one or a defined one (1%-100%) when switching on the luminaries. It is able to set a delay time (changing time) to dim UP the luminaries or dim UP gradually in the default period. When receiving the OFF message, the dimmer will be switched off immediately, or dim DOWN gradually after a delay time (changing time) or in the default changing period.

Relative dimming

4 data bits control: the relative dimming command means it is possible to dim UP or DOWN to the needed brightness value during the set brightness threshold range. It is only valid to dim UP when the brightness value is smaller than the low threshold value and dim DOWN when the brightness value is greater than the high threshold value. It is also able to set whether to switch on the luminaries by the message "dim UP to a certain value" when the output is 0 by this function. The relative dimming is used to control the relative changes of the brightness by 4 data bits: the lowest 3 bits are controlling-bit and the highest bit is----- "1" means dim UP, "0" means dim DOWN.

Explanation of setting relative dimming: (1-7: dim DOWN; 0-8 remain unchanged (stop dimming); 9-15 dim UP)

Parameter	0	1	2	3	4	5	6	7
Dim DOWN	Unchange/ stop dimming	255	128	64	32	16	8	4

Parameter	8	9	10	11	12	13	14	15
Dim UP	Unchange/ stop dimming	255	128	64	32	16	8	4

Absolute dimming

8 data bits control: it is able to dim to the needed brightness value by changing the brightness parameters. The setting of the parameters is similar as relative dimming with the brightness value range: one low threshold value and one high threshold value. And it is not allowed to change the brightness value beyond the set range, the max. range is from 0 to 255. This function offers the possibility to dim UP or DOWN to 0 gradually to the target value by setting the delay time or the default time.

The high and low threshold value limits the total output of the dimmer; any brightness value beyond the range is not valid.

When the output is 0, it is able to set switching off the luminaries or remaining to a lower brightness value; and also in this status it is optional to switch on the luminaries by receiving the message "absolute dimming".

Status Report

1 data bit: the dimmer offers the possibility whether sending the latest brightness value report of the controlled target and the changed report of the switch status to the BUS.

Scene

8 data bits control: the dimmer offers 15 (1-15) scenes for selection. It is possible to set ONE brightness value and the gradual change time of ON for each scene. After setting, it is easy to call any favorite scene. 1 in the highest bit of the scene command it means "saving" command, to save the current brightness value to the relevant scene.

Preset Value

The dimmer can preset scene, the object directly through 1bit data to transfer the preset scene or through 1bit data to let favorite scene to replace original preset scene. There are two preset values per output, there are two brightness values can be transfer for each preset value. Such as in theater, we need a relatively bright lighting effect when coming in, we can through transfer the first brightness value to be achieved this effect, when the movie starts playing, we need a relatively dark lighting effect, we can through transfer the second brightness value to be achieved. We can return to the previous brightness value when the movie ended.

Staircase Lighting Function

The dimmer offers the function of staircase lighting control besides the normal lighting control.

The staircase lighting function serves to switch off the lighting directly until dimming DOWN to 20% of the brightness value after a set period. It is able to set the brightness of the luminaries, the duration of the light ON, the time to dim down to 20% separately.

In this function, it uses 1 data bit control the targets directly by setting a permanent fixed value to the output of the staircase luminaries.

The steps of staircase lighting control: the staircase luminaries will be switched on for a certain time (this time can be set) if the controlled target receives the message of "1"; these luminaries will be switched on again when receiving another message "1" during this period. The luminaries will be switched off when they are dimmed down to 20% of the brightness value (the dim down time can be set) after this period, or switch off the luminaries by sending message "0" to the controlled target. The luminaries will be off after dimming down to 20% when receiving the message "0" (the same dimming down time as above). When enabling the function "On reception switch OBJ=0 switch off", it is able to use the function "switch off" to turn off the output in the status of "permanent on", or change the status from "switch on" to "permanent on" (message "1" means ON, "0" means OFF).

Reset

When the BUS is power off, all the outputs are switched off; the current brightness value will be saved to the memory of the dimmer. When the BUS voltage is recovered, the brightness status may be the last brightness value, or the preset brightness value.

When the BUS is power off, it may have the following situation occurring:

In the normal mode, 2 optional behaviors after the BUS voltage recovery are: the last brightness value before power off, or the set value.

In the staircase lighting mode, the behavior after the BUS voltage recovery is: ON or OFF. No output when it is OFF; start the behavior "switch=1" when it is ON.